



# 200 Series Regulators

# 205 SERIES

The 205 Series regulators are intended for secondary pressure control of non-corrosive, high purity or liquefied gases (up to grade 4.5) or as point of use pressure control in high purity gas distribution systems.

- Single Stage
- Chrome-Plated Forged Brass Body
- 316L Stainless Steel Diaphragm
- Four Port Configuration



205 3021-000 shown

## Typical Applications

- Point-of-use laboratory systems
- Gas supply purging
- Liquefied hydrocarbon gas control
- Control of cryogenic gases
- Bulk gas distribution systems

## Features

- CAPSULE® Seat**  
Increased serviceability and life
- 316L Stainless Steel Diaphragm**  
No inboard diffusion
- Forged Body**  
Durable, long-lasting construction
- Field-Adjustable Pressure Limit**  
Safeguard downstream equipment
- Large Convoluted Diaphragm**  
Smooth pressure changes
- Standard Relief Valve**  
Diaphragm and gauge protection
- Chrome-Plated Forged Brass Body**  
Economical high purity design
- High Flow Capacity**  
Supply multiple user locations
- Pressure Ranges 0-15 to 0-200 PSIG (0-1 to 0-14 BAR)**  
Broad range of applications
- 3000 PSIG (210 BAR) Inlet Pressure Rating**  
Safe use with high pressure cylinders

## Materials

- Body**  
Chrome-plated forged brass
- Bonnet**  
Chrome-plated die-cast zinc
- Seat**  
PTFE
- Filter**  
10 micron sintered bronze
- Diaphragm**  
316L stainless steel
- Internal Seals**  
PTFE

## Specifications

- Maximum Inlet Pressure**  
3000 PSIG (210 BAR)
- Temperature Range**  
-40°F to 140°F (-40°C to 60°C)
- Gauge**  
2 1/2" (68mm) diameter chrome-plated brass
- Ports**  
1/4" FPT
- Helium Leak Integrity**  
1 x 10<sup>-8</sup> scc/sec
- Cv**  
0.28  
*See page 192 for flow curves*
- Weight (205 3021-000)**  
3.2 lbs. (1.44 kg)

# 200 Series Regulators



## Installation Dimensions

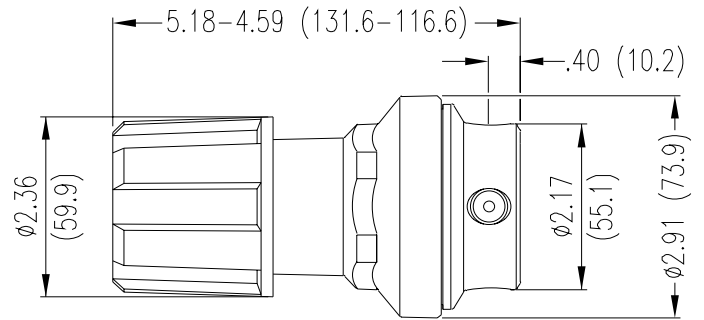
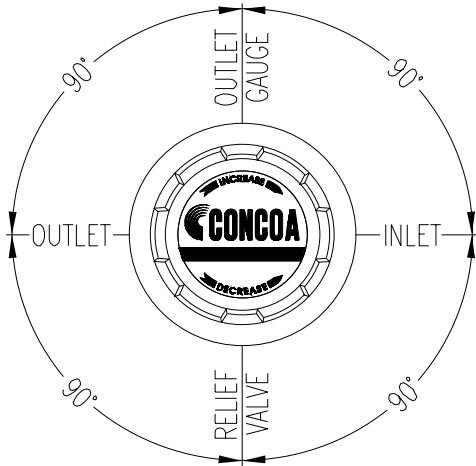

## Ordering Information

205	A	B	C	D	-CON	Options	
Series 205	Outlet Pressure	Outlet Gauge	Inlet Gauge	Outlet Assemblies	Assembly Gauges	Inlet Connections	Installed Options
	<b>1:</b> 0-15 PSIG (0-1 BAR)	0-30 PSIG/ 0-2 BAR	<b>0:</b> None	<b>0:</b> 1/4" FPT port	<b>0:</b> Bare body	<b>000:</b> 1/4" FPT	<b>M:</b> Protocol station
	<b>2:</b> 0-40 PSIG (0-3 BAR)	0-60 PSIG/ 0-4 BAR		<b>1:</b> 1/4" MPT	<b>1:</b> Standard assembly (PSIG/kPa gauges)	<b>TF2:</b> 1/8" tube	<b>Q:</b> Protocol purge station
	<b>3:</b> 0-120 PSIG (0-8 BAR)	0-200 PSIG/ 0-14 BAR		<b>2:</b> 1/4" tube fitting	<b>2:</b> Standard assembly (BAR/PSIG gauges)	<b>TF4:</b> 1/4" tube	
	<b>4:</b> 0-200 PSIG (0-14 BAR)	0-400 PSIG/ 0-27 BAR		<b>3:</b> Diaphragm valve 1/4" tube fitting	<b>6:</b> Mirror image assembly (PSIG/kPa gauges)	<b>TF6:</b> 3/8" tube	
	<b>5:</b> 0-15 PSIG (0-1 BAR)*	0-30 PSIG/ 0-2 BAR		<b>4:</b> Diaphragm valve 1/4" MPT	<b>7:</b> Mirror image assembly (BAR/PSIG gauges)	<b>M06:</b> 6mm tube	
	<i>*With redline for acetylene use</i>			<b>5:</b> Needle valve 1/4" MPT			
				<b>6:</b> 1/8" tube fitting			
				<b>7:</b> 3/8" tube fitting			
				<b>8:</b> Diaphragm valve 1/8" tube fitting			
				<b>9:</b> Diaphragm valve 1/4" FPT			
				<b>A:</b> 3/8" BSP RH fitting			
				<b>B:</b> Diaphragm valve 3/8" tube fitting			
				<b>C:</b> 3/8" BSP LH fitting			
				<b>D:</b> 6mm brass hose barb (Not available if A=4 or 5)			
				<b>G:</b> 1/8" stainless steel tube fitting			
				<b>H:</b> 1/4" stainless steel tube fitting			
				<b>M:</b> 6mm tube fitting			
				<b>S:</b> Diaphragm valve 6mm tube fitting			

