



400 Series Regulators

432 SERIES

The 432 Series regulators are intended for primary pressure control of ultra-high purity or corrosive gases for applications requiring constant pressure control and delivery regardless of supply pressure variations.

- Dual Stage
- 316L Stainless Steel Barstock Body
- Six Port Configuration
- 316L Stainless Steel Diaphragm

Typical Applications

- EPA protocol gases
- Gas and liquid chromatography
- High purity carrier gases
- Zero, span, and calibration gases
- Ultra-high purity chamber pressurization
- Liquefied hydrocarbon gas control
- Corrosive gases



432 3331-580 shown

Features	Materials	Specifications
<p>Metal-to-Metal Diaphragm Seal No possibility of gas contamination</p> <p>CAPSULE® Seat Increased serviceability and life</p> <p>316L Stainless Steel Barstock Body Increased corrosion resistance</p> <p>Front Panel-Mountable Easy installation</p> <p>10 Micron Filtration in Both Stages Fail-safe seat performance</p> <p>Pressure Ranges 0-15 to 0-350 PSIG (0-1 BAR to 0-24 BAR) Broad range of applications</p> <p>Pipe Away Relief Valve Safely vents exhaust gases</p>	<p>Body 316L stainless steel barstock</p> <p>Bonnet Chrome-plated brass barstock</p> <p>Seat PTFE PCTFE with 3500 PSIG (240 BAR) or 4500 PSIG (310 BAR) inlet option</p> <p>Filter Patented 10 micron 316 mesh</p> <p>Diaphragm 316L stainless steel</p> <p>Internal Seals PTFE</p>	<p>Maximum Inlet Pressure 3000 PSIG (210 BAR) 3500 PSIG (240 BAR) optional 4500 PSIG (310 BAR) optional</p> <p>Temperature Range -40°F to 140°F (-40°C to 60°C)</p> <p>Gauges 2" (53mm) diameter stainless steel</p> <p>Ports 1/4" FPT</p> <p>Helium Leak Integrity 1 x 10⁻⁹ scc/sec</p> <p>Cv 0.1 <i>See page 188 for flow curves</i></p> <p>Weight (432 3331-580) 5.09 lbs. (2.31 kg)</p>

400 Series Regulators



Installation Dimensions

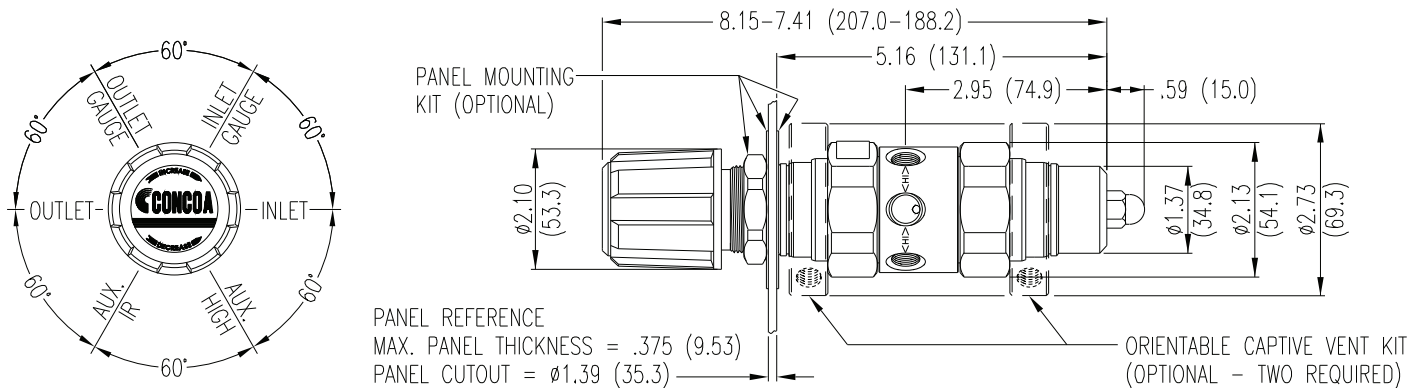

Ordering Information

432	A	B	C	D	-CON	Options	
Series 432	Outlet Pressure	Outlet Gauge	Inlet Gauge	Outlet Assemblies	Assembly/ Gauges	Inlet Connections	Installed Options
	1: 0-15 PSIG (0-1 BAR)	30"-0-30 PSIG/ -1-0-2 BAR)	0: None	0: 1/4" FPT port	0: Bare body	000: 1/4" FPT	B: Protocol alarm station (110/220 VAC)
	2: 0-50 PSIG (0-3.5 BAR)	30"-0-100 PSIG/ -1-0-7 BAR	3: 0-4000 PSIG/ 0-275 BAR	1: 1/4" MPT	1: Cleanroom assembly (PSIG/kPa gauges)	TF2: 1/8" tube	C: Protocol switchover station
	3: 0-100 PSIG (0-7 BAR)	30"-0-200 PSIG/ -1-0-14 BAR	5: 0-1000 PSIG/ 0-70 BAR	2: 1/4" tube fitting	2: Cleanroom assembly (BAR/PSIG gauges)	TF4: 1/4" tube	D: Deep purge*
	4: 0-250 PSIG (0-17 BAR)	0-400 PSIG/ 0-27 BAR	6: 0-300 PSIG/ 0-21 BAR	3: Diaphragm valve 1/4" tube fitting		TF6: 3/8" tube	H: Protocol switchover station with alarm (110/220 VAC)
	7: 0-150 PSIG (0-10 BAR)	30"-0-200 PSIG/ -1-0-14 BAR	7: 0-400 PSIG/ 0-27 BAR	4: Diaphragm valve 1/4" MPT		M06: 6mm tube	M: Protocol station
	E: 0-350 PSIG (0-24 BAR)	0-400 PSIG/ 0-27 BAR	8: 0-6000 PSIG/ 0-405 BAR*	5: Needle valve 1/4" MPT		CGA DIN 477 BS 341 and others available	Q: Protocol purge station*
			G: 0-4000 PSIG/ 0-275 BAR†	6: 1/8" tube fitting			S: Stainless steel bonnets
			*Maximum inlet pressure 4500 PSIG (310 BAR) with PCTFE seat CAPSULE®	7: 3/8" tube fitting			*Not available with 4500 PSIG (310 BAR) max inlet pressure
			†Maximum inlet pressure 3500 PSIG (240 BAR) with PCTFE seat CAPSULE®	8: Diaphragm valve 1/8" tube fitting			
				9: Diaphragm valve 1/4" FPT			
				M: 6mm tube fitting			
				S: Diaphragm valve 6mm tube fitting			

Related Options

Order No.	Description
550 0002	Panel mount kit
550 0001	Captured vent kit (2 required)
476 0002	Helium Leak certification

